

# MODEL NH38-5RZ

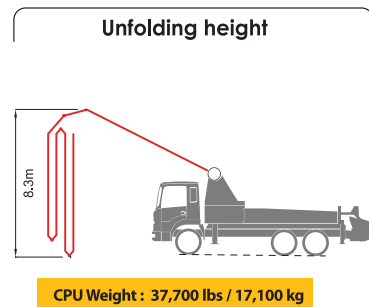
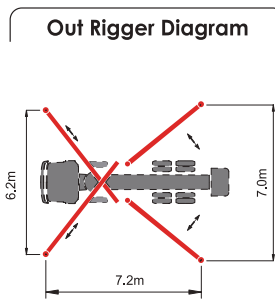
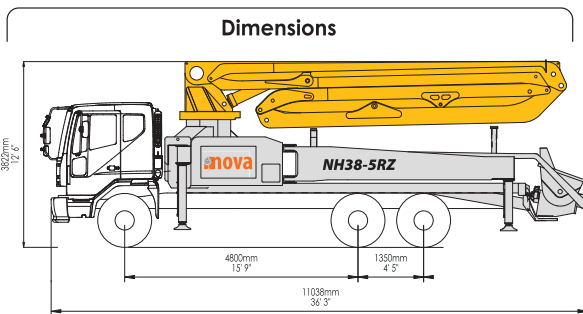

### Boom Specification

Spec	U.S.	Metric
Number of Booms	5 Sections	
Folding Type	RZ Folding	
Vertical Reach	122' 8"	37.4 m
Horizontal Reach	109' 7"	33.4 m
Reach Depth	72' 2"	22.0 m
Unfolding Height	27' 3"	8.3 m
Section Articulation	90°/180°/180°/245°/230°	
Rotation	370°	
Delivery Line	5"	125 mm
Proportional Boom	Yes	
End Hose Length	13' 2"	4.0 m
Out Rigger Spread - Front	20' 5"	6.2 m
Out Rigger Spread - Rear	22' 11"	7.0 m

### Pump Specification

Spec	U.S.	Metric
Maximum Output	209.3 yd <sup>3</sup> /h	160 m <sup>3</sup> /h
Concrete Pressure	1015 psi	70 bar
Stroke Per Min.	30	
Delivery Cylinder	Ø 9"	Ø 230
Stroke Length	6' 11"	2100 mm
S-Valve	Ø8" x Ø7"	Ø200 x Ø180 mm
Hydraulic System Pressure	5076 psi	350 bar
Hydraulic Pump	Rexroth A11VLO260	
Switching Type	Hydraulic	
Hopper Capacity	21.2 ft <sup>3</sup>	600 liter
Max. Aggregate Size	1.6"	40 mm
Water Pump Pressure	290 psi	20 bar
Water Tank Capacity	17.7 ft <sup>3</sup>	500 liter

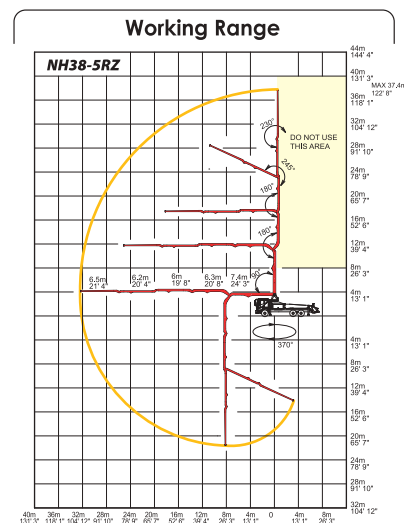

# MODEL NH38-5ZR

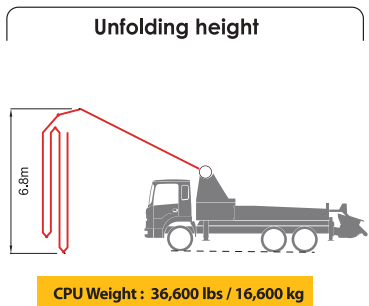
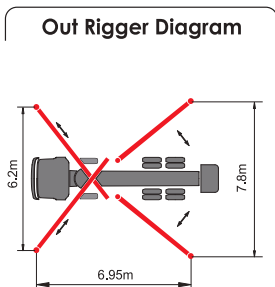
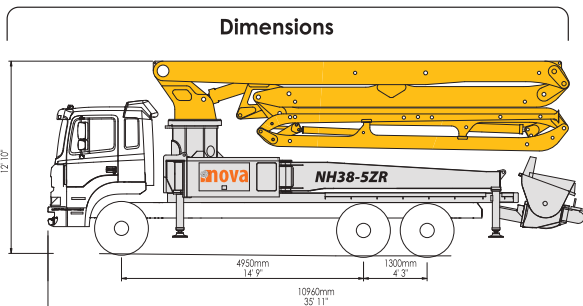

### Boom Specification

Spec	U.S.	Metric
Number of Booms	5 Sections	
Folding Type	ZR Folding	
Vertical Reach	123' 4"	37.6 m
Horizontal Reach	110' 3"	33.6 m
Reach Depth	70' 6"	21.5 m
Unfolding Height	22' 4"	6.8 m
Section Articulation	92°/180°/245°/180°/240°	
Rotation	370°	
Delivery Line	5"	125 mm
Proportional Boom	Yes	
End Hose Length	13' 2"	4.0 m
Out Rigger Spread - Front	20' 4"	6.2 m
Out Rigger Spread - Rear	25' 7"	7.8 m

### Pump Specification

Spec	U.S.	Metric
Maximum Output	209.3 yd <sup>3</sup> /h	160 m <sup>3</sup> /h
Concrete Pressure	1015 psi	70 bar
Stroke Per Min.	30	
Delivery Cylinder	Ø 9"	Ø 230
Stroke Length	6' 11"	2100 mm
S-Valve	Ø8" x Ø7"	Ø200 x Ø180 mm
Hydraulic System Pressure	5076 psi	350 bar
Hydraulic Pump	Rexroth A11VLO260	
Switching Type	Hydraulic	
Hopper Capacity	21.2 ft <sup>3</sup>	600 liter
Max. Aggregate Size	1.6"	40 mm
Water Pump Pressure	290 psi	20 bar
Water Tank Capacity	17.7 ft <sup>3</sup>	500 liter

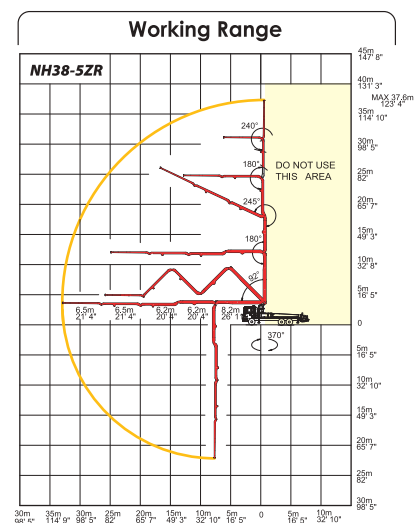

Dimensions and weights of drawings will vary with different chassis models, specifications and local or national regulations. Any specific options, please contact info@novaintl.ca